

## Помпи центробежни едностъпални

**city**<sup>®</sup>  
**pumps**

### RANGE OF PERFORMANCE

Flow rate up to 600 l/min (36 m<sup>3</sup>/h)  
Head up to 39 m

### LIMITS OF USE

Manometric suction lift up to 7 m  
Liquid temperature up to + 90°C  
Environment temperature up to + 40°C



### INSTALLATION AND USE

THE ICH SERIES IS RECOMMENDED FOR CIVIL, AGRICULTURAL AND INDUSTRIAL APPLICATIONS. THE HIGH FLOW RATES AND CONTINUOUS RATING MAKE IT IDEAL FOR IRRIGATION WITH FLOWING AND SPRINKLING WATER, FOR DRAWING WATER FROM LAKES, RIVERS, WELLS, OR FOR INDUSTRIAL APPLICATIONS THAT NEED TO ACHIEVE LARGE FLOW RATES AT MEDIUM-LOW HEADS.

The pumps must be installed in enclosed places, or at least protected against inclement weather.

**GUARANTEE 2 YEARS** subject to our general terms of sale.

### CONSTRUCTION CHARACTERISTICS

- **PUMP BODY:** cast iron, with threaded ports ISO 228/1.
- **IMPELLER:** brass, of the type with centrifugal radial flow.

### • MOTOR SHAFT:

stainless steel EN 10088-3 - 1.4104.

### • MECHANICAL SEAL:

ceramic - graphite - NBR.

• **ELECTRIC MOTOR:** the pumps are close-coupled to a carefully matched electric motor, quiet running, totally enclosed fan cooled, suitable for continuous duty.

**ICH M:** single-phase 230 V - 50 Hz with capacitor and thermal overload protector.

**ICH:** three-phase 230/400 V - 50 Hz.

• **INSULATION:** class F.

• **PROTECTION:** IP 44.

### OPTIONS ON REQUEST

⇒ special mechanical seal

⇒ other voltages or frequency 60 Hz

### CONSTRUCTION AND SAFETY STANDARDS

EN 60034-1

IEC 34-1

CEI 2-3



## DIMENSIONS

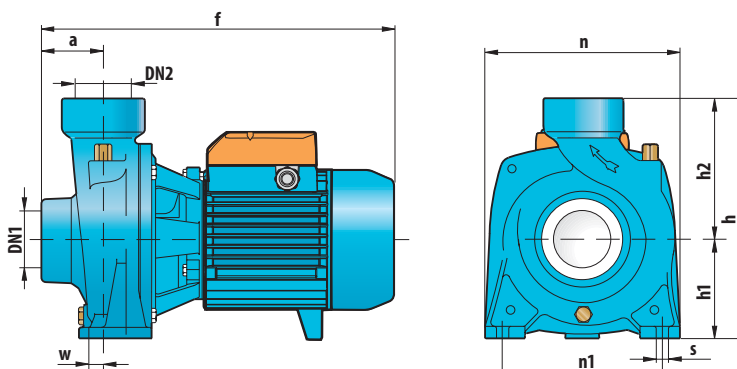



## ICH

centrifugal pumps - medium flow rates

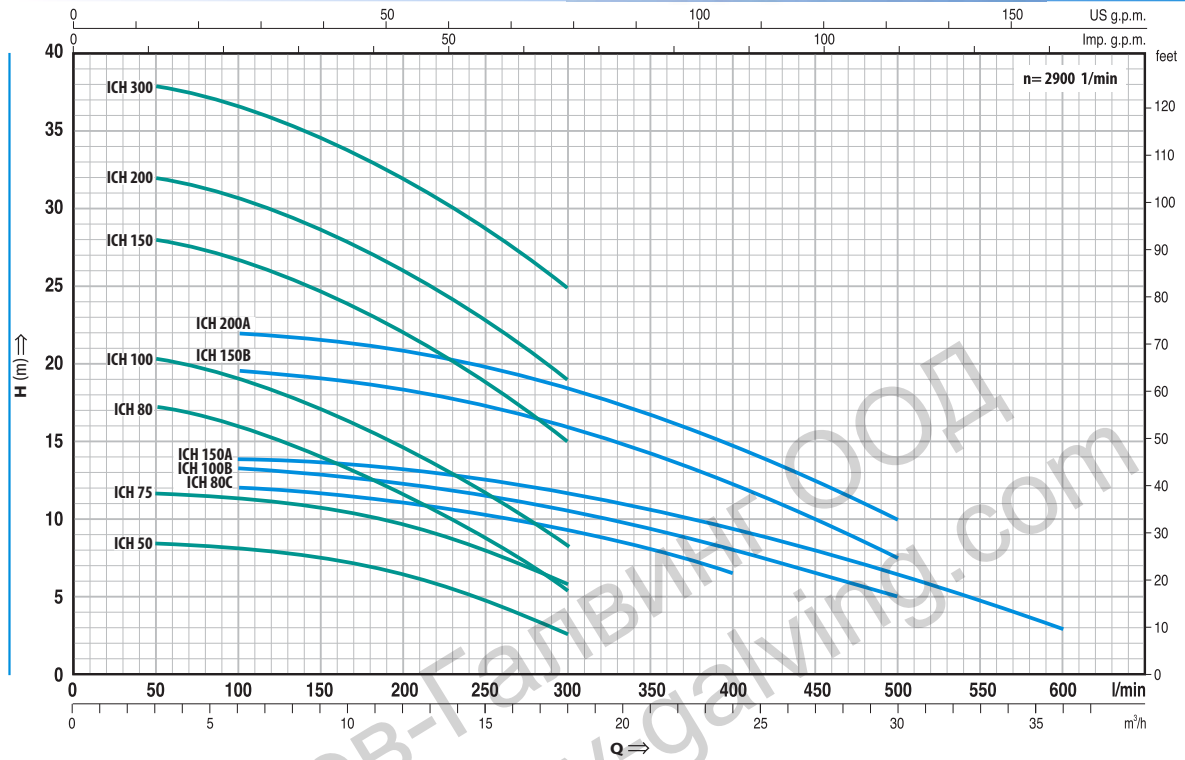

Q = Flow rate H = Total manometric head

Tolerance of the performance curves according to EN ISO 9906 App. A.

TYPE		POWER		m³/h	H metres												
Single-phase	Three-phase	kW	HP		0	3	6	9	12	15	18	21	24	30	36		
ICH 50M	ICH 50	0.37	0.50	0	0	50	100	150	200	250	300	350	400	500	600		
ICH 75M	ICH 75	0.55	0.75	9	8.5	8.2	7.5	6.3	4.9	2.8							
ICH 80M	ICH 80	0.60	0.85	12	11.5	11.2	10.6	9.6	8	6							
ICH 100M	ICH 100	0.75	1	18.2	17.2	16	14	11.5	9	5.4							
ICH 150M	ICH 150	1.1	1.5	21.2	20.2	19	17	14.5	11.6	8.4							
ICH 200M	ICH 200	1.5	2	29	28	26.5	24.5	22	18.5	15							
---	ICH 300	2.2	3	33	32	30.5	28.5	26	22.5	19							
ICH 80CM	ICH 80C	0.60	0.85	39	38	36.5	34.5	32	28.5	25							
ICH 100BM	ICH 100B	0.75	1	12.5	-	12	11.7	11	10.2	9.2	8	6.5					
ICH 150AM	ICH 150A	1.1	1.5	13.7	-	13.2	13	12.5	11.6	10.5	9.2	8	5				
ICH 150BM	ICH 150B	1.1	1.5	14.5	-	13.8	13.5	13.2	12.6	11.8	10.5	9.2	6.5	3			
ICH 150BM	ICH 150B	1.1	1.5	20.2	-	19.2	19	18	17	16	14	12	7.5				
ICH 200AM	ICH 200A	1.5	2	22.5	-	22	21.5	21	20	18.5	16.6	14.5	10				

## DIMENSIONS AND WEIGHTS

TYPE		PORTS		DIMENSIONS mm										kg	
Single-phase	Three-phase	DN1	DN2	a	f	h	h1	h2	n	n1	w	s	1~	3~	
ICH 50M	ICH 50	1 1/2"	1 1/2"	45	276	200	82	118	165	135	1	10	8.3	8.2	
ICH 75M	ICH 75				283/276								8.9	8.4	
ICH 80M	ICH 80				300								15.5	15.1	
ICH 100M	ICH 100			48.5	373	225	92	133	190	160	4	12	12	13.0	12.1
ICH 150M	ICH 150													20.0	19.3
ICH 200M	ICH 200													22.2	21.6
---	ICH 300	-	-	-	-	-	-	-	-	-	-	-	22.8		
ICH 80CM	ICH 80C	2"	2"	60	332	238	97	141	196	160	14	11	15.3	14.2	
ICH 100BM	ICH 100B												15.1	14.3	
ICH 150AM	ICH 150A												15.5	15.2	
ICH 150BM	ICH 150B												20.3	19.5	
ICH 200AM	ICH 200A	51	386	260	110	150	206	206	1	1	1	22.2	21.8		